

EURO

Forno elettrico modulare per pizzeria, pasticceria e panetteria

Modular electric oven for pizza, pastry and bread



EURO CLASSIC - EC9 I/R

CARATTERISTICHE TECNICHE

- 1 - 2 - 3 camere di cottura interamente in materiale refrattario con piano di cottura e cielo ad alte prestazioni e resistenza
- Resistenze corazzate "hy-pe" in acciaio inossidabile integrate nel refrattario del piano di cottura e resistenze cielo a vista.
- Pannello di controllo digitale
- Controllo delle potenze del piano di cottura e del cielo separate
- Isolamento termico
- Massima temperatura di cottura 450 °C
- Valvola regolabile per scarico vapori
- Sportello con finestra in vetro temperato
- Sportelli frontali controbilanciati
- Lampade alogene ad alta resistenza e capacità luminosa
- Disponibile in acciaio inossidabile

ACCESSORI

- Cella di lievitazione ermetica
- Supporto del forno
- Modulo cappa

OPTIONAL

- Vaporiera (assorbimento massimo 1,4 Kw)
- Kit abbattimento vapori e odori con filtro ai carboni attivi (assorbimento massimo 0,7 Kw)
- 4 ruote (h = 16 cm + 2 cm per la cella di lievitazione)
- Piedi per celle di lievitazione (h min = 8 cm / max = 20 cm)

VERSIONI

- Disponibile in versione **EURO "STAND"** - **ES9 /I** con 1 - 2 - 3 camere di cottura in acciaio alluminato con piano cottura in refrattario
- Piano di cottura e cielo con resistenze corazzate in acciaio inox

TECHNICAL SPECIFICATIONS

- 1 - 2 - 3 cooking chambers in full refractory material with high resisting and performing baking floor and ceiling
- Stainless steel armoured heating elements "hy-pe" integrated in the refractory floor and exposed top resistors.
- Digital control panel
- Top and bottom separate power control
- Thermal insulation
- Max cook temp 450 °C
- Adjustable steam exhaust valve
- Single tempered glazed door
- Counter balanced door
- High resistance and efficiency halogen lamps
- Available in stainless steel

ACCESSORIES

- Hermetic prover
- Oven support
- Hood module

OPTIONALS

- Steam injection system (max. absorption 1,4 Kw)
- Steam and odours damper kit for hood with active carbon filter (max. absorption 0,7 Kw)
- 4 wheels (h = 16 cm + 2 cm for the prover)
- Feet for provers (h min = 8 cm / max = 20 cm)

VERSIONS

- Available in **EURO "STAND"** - **ES9 /I** version with 1 - 2 - 3 cooking chambers in aluminium coated steel plate with refractory cooking floor
- Top and bottom stainless steel armoured heating elements

ITALFORNI È UN BRAND DI WAICO GROUP

ITALFORNI - Sede operativa
Via dell'Industria, 130 - Loc. Chiusa di Ginestreto
61122 Pesaro (PU) Italia - Tel. +39 0721 481515
italforni@waicogroup.com - www.italforni.it

WAICO srl - Sede legale
Via Scotte, 1 - Isola Vicentina
36033 Vicenza (VI) Italia - Tel. +39 0445 1716598
info@waicogroup.com - www.waicogroup.com

1 CAMERA + SUPPORTO ALTO
1 DECK + HIGH STAND

✓ ALLACCIO ELETTRICO
ELECTRIC CONNECTION

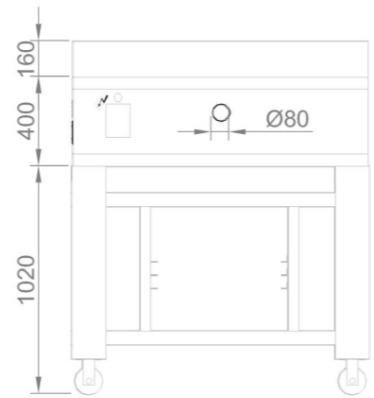
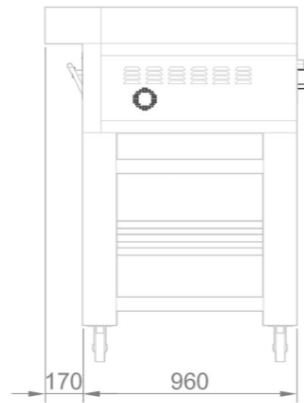
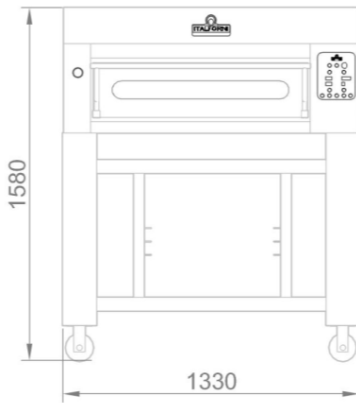

1 CAMERA + CELLA DI LIEVITAZIONE ALTA
1 DECK + HIGH PROVER

✓ ALLACCIO ELETTRICO
ELECTRIC CONNECTION

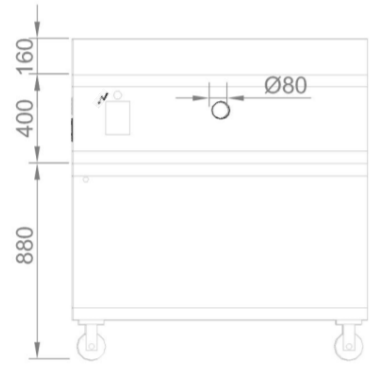
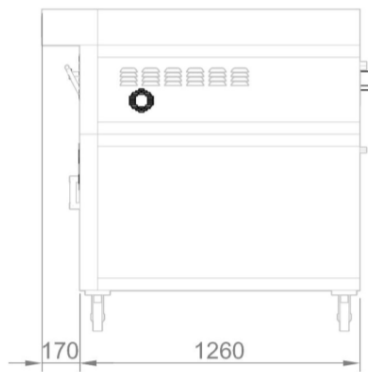
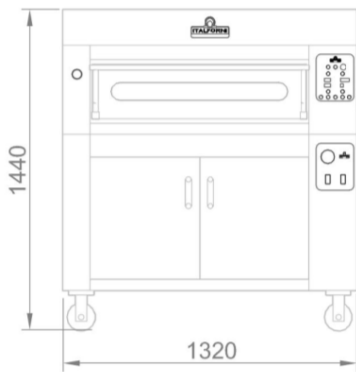

2 CAMERE + SUPPORTO ALTO
2 DECKS + HIGH STAND

✓ ALLACCIO ELETTRICO
ELECTRIC CONNECTION

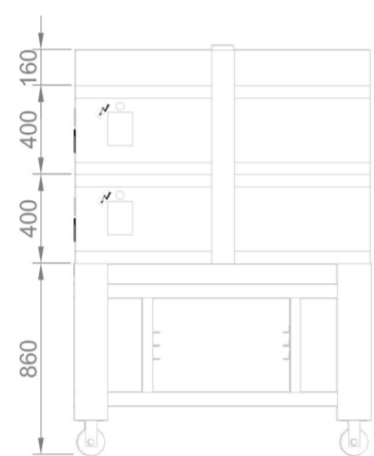
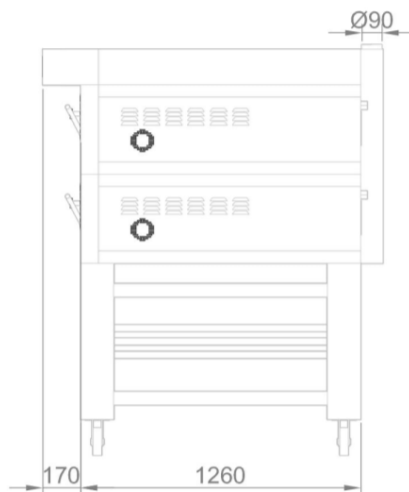
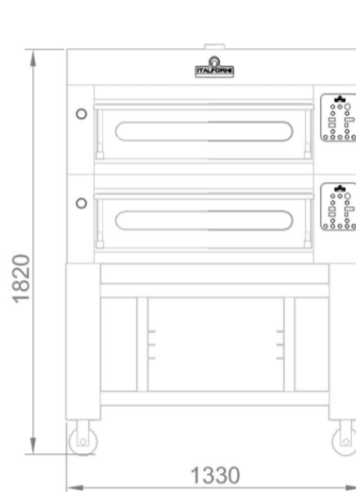

ITALFORNI È UN BRAND
DI WAICO GROUP

ITALFORNI - Sede operativa
Via dell'Industria, 130 - Loc. Chiusa di Ginestreto
61122 Pesaro (PU) Italia - Tel. +39 0721 481515
italforni@waicogroup.com - www.italforni.it

WAICO srl - Sede legale
Via Scotte, 1 - Isola Vicentina
36033 Vicenza (VI) Italia - Tel. +39 0445 1716598
info@waicogroup.com - www.waicogroup.com

2 CAMERE + CELLA DI LIEVITAZIONE ALTA
2 DECKS + HIGH PROVER

ALLACCIO ELETTRICO
 ELECTRIC CONNECTION

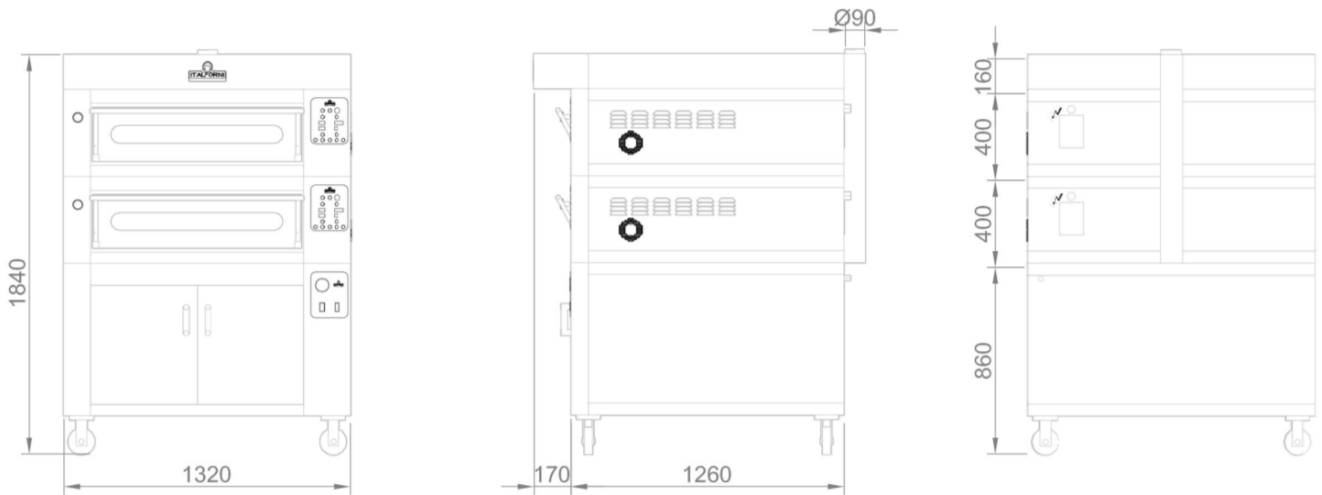

3 CAMERE + SUPPORTO BASSO
3 DECKS + LOW STAND

ALLACCIO ELETTRICO
 ELECTRIC CONNECTION

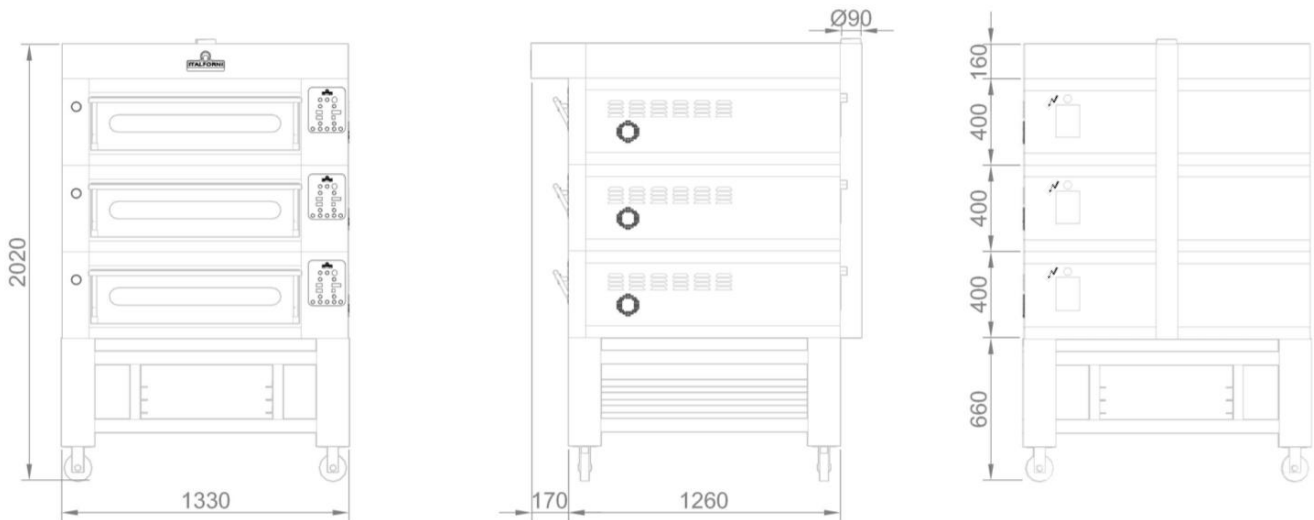

3 CAMERE + CELLA DI LIEVITAZIONE BASSA
3 DECKS + LOW PROVER

ALLACCIO ELETTRICO
 ELECTRIC CONNECTION

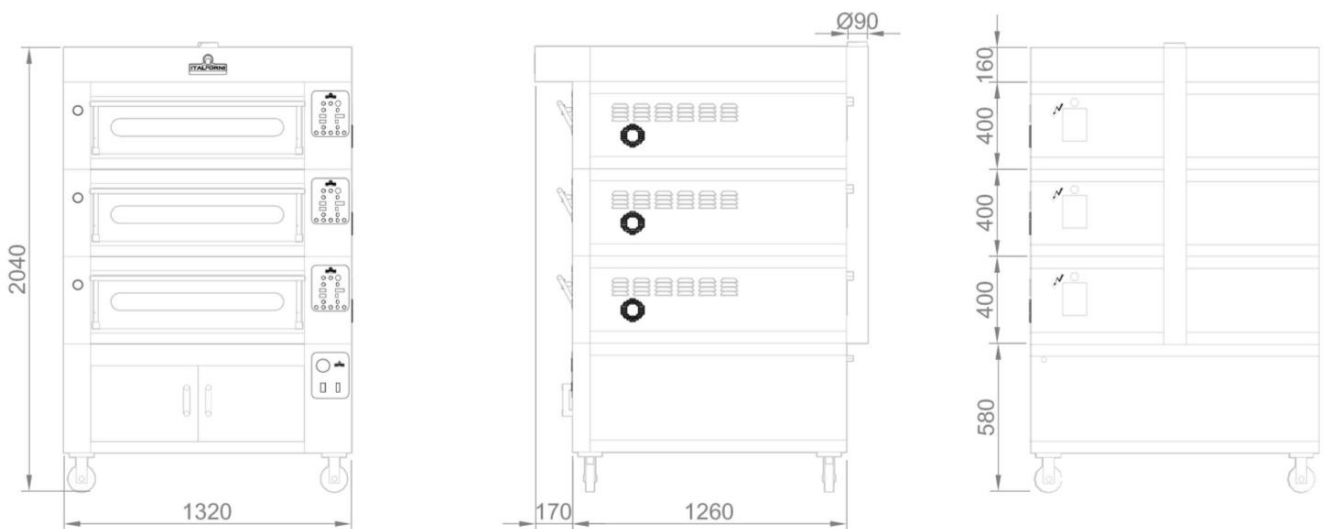

ITALFORNI È UN BRAND
 DI WAICO GROUP

ITALFORNI - Sede operativa
 Via dell'Industria, 130 - Loc. Chiusa di Ginestreto
 61122 Pesaro (PU) Italia - Tel. +39 0721 481515
 italforni@waicogroup.com - www.italforni.it

WAICO srl - Sede legale
 Via Scotte, 1 - Isola Vicentina
 36033 Vicenza (VI) Italia - Tel. +39 0445 1716598
 info@waicogroup.com - www.waicogroup.com

VALVOLA REGOLABILE PER SCARICO VAPORI
ADJUSTABLE STEAM EXHAUST VALVE

Vista dall'alto 1 camera
Top view 1 deck

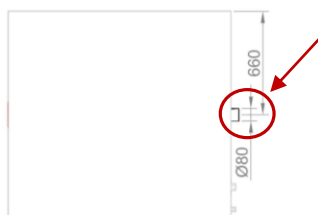

Vista dall'alto 2 o 3 camere
Top view 2 or 3 decks

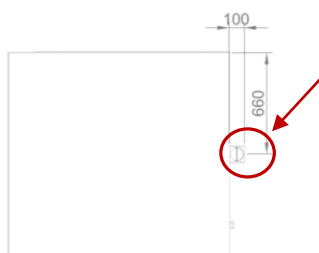

VAPORIERA
STEAM INJECTION SYSTEM

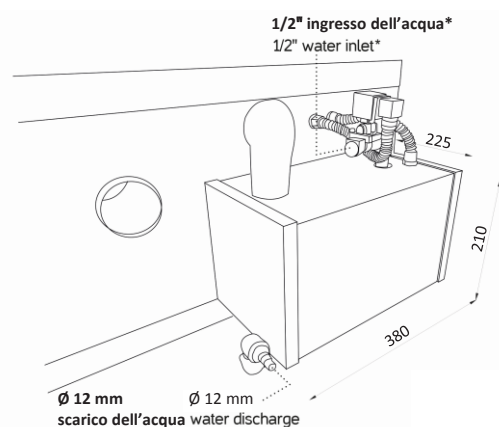

*Deve essere installato un riduttore di pressione massima di 0.5/0.6 bar
*0.5/0.6 bar max pressure reduce has to be installed
Assorbimento massimo 1,4 Kw
Max. absorption 1,4 Kw

CAPACITÀ DI CARICO PER CAMERA
LOADING CAPACITY PER DECK

EC9 I/R
ES9 I/R

DIMENSIONI INTERNE
Internal dimensions
A/H 17 x L/W 93 x P/D 93 cm
9 Pizze Ø 30 cm
2 Teglie 60x40 cm
2 Baking pans 60x40 cm

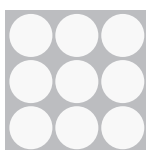

DATI TECNICI
TECHNICAL CHART



Euro	Dimensioni interne (cm)			Dimensioni esterne (cm)			Peso	Alimentazione	Potenza	Potenza	Assorbimento	Temperatura	N° Teglie
	Internal dimensions (cm)			External dimensions (cm)			Weight	Supply	Power	Power	Absorption	Temperature	# Baking pans
	A/H	L/W	P/D	A/H	L/W	P/D	KG	V/Ph/Hz	KW	KW/h	Ampere	°C	60x40 cm
EC9 / ES9 I/R - DECK	17	93	93	40	132	126	200/165	400/3/50-60	9,5	4,5	15	0/450	
KC9 / KS9 - HOOD				16	132	143	37						
BC9 / BS9 - PROVER				70/50	132	126	110/95	230/1/50-60	1	0,5		0/90	14/6
SEC9 / SES9 - STAND				86/70/50	133	126	52/47/40						24/9/9

I = Frontale Acciaio Inox / Stainless Steel Front

R = Frontale rustico / Country Style Front

ITALFORNI È UN BRAND
DI WAICO GROUP

ITALFORNI - Sede operativa
Via dell'Industria, 130 - Loc. Chiusa di Ginestreto
61122 Pesaro (PU) Italia - Tel. +39 0721 481515
italforni@waicogroup.com - www.italforni.it

WAICO srl - Sede legale
Via Scotte, 1 - Isola Vicentina
36033 Vicenza (VI) Italia - Tel. +39 0445 1716598
info@waicogroup.com - www.waicogroup.com

CE I dati riportati sul presente documento sono da ritenersi non vincolanti. Waico srl si riserva di apportare modifiche tecniche in qualsiasi momento.
The specifics shown in this document are to be considered not binding. Waico srl reserves the right to make technical changes at any moment.