

DIAMOND

Forno elettrico modulare per pizzeria, pasticceria e panetteria

Modular electric oven for pizza, pastry and bread



DIAMOND

CARATTERISTICHE TECNICHE

TECHNICAL SPECIFICATIONS

	Un design scenografico ad effetto diamante A spectacular design with a shining effect		Isolamento termico garantito Guaranteed thermal insulation
	Superficie alluminio disponibile in 4 colorazioni Aluminium surface available in 4 colours		La temperatura esterna del forno rimane sui 30°C The external temperature of the oven remains around 30°C
	Meccanismi e ferramenta a scomparsa Hidden mechanisms and hardware		Sportelli frontali controbilanciati Counter-balanced front doors
	Touch screen 65K, funzionalità e semplicità in un touch Touch screen 65K, functionality and simplicity with a touch		Visione completa dell'interno della camera di cottura Complete view of the cooking chamber inside
	Funzioni ipertecnologiche Hyper-technological functions		Illuminazione camera Chamber lighting
	Minor dispersione verso l'esterno Less outwards heat dispersion		Manutenzione semplificata Simplified maintenance
	Regolazione digitale separata potenza cielo e piano di cottura Independent digital power regulation for baking floor and ceiling		3 forni in 1: Pizzeria, Pasticceria e Panetteria 3 ovens in 1: Pizza, Pastry and Bread
	Camera di cottura totalmente rivestita in materiale refrattario Cooking chamber fully coated with refractory material		Ultra velocità di riscaldamento Ultra fast heating
	Resistenze corazzate Hype inserite nel piano refrattario e resistenze cielo a vista Armored heating elements Hype inserted inside the baking floor and ceiling heating elements exposed		Produzione fino a 9 pizze Ø35 cm per camera di cottura Production up to 9 pizzas Ø35 cm for each baking chamber
	450°C di temperatura massima di cottura Maximum cooking temperature 450°C		Rivestimento in alluminio totalmente riciclabile Aluminium coating, totally recyclable

**ITALFORNI È UN BRAND
DI WAICO GROUP**

ITALFORNI - Sede operativa
Via dell'Industria, 130 - Loc. Chiusa di Ginestreto
61122 Pesaro (PU) Italia - Tel. +39 0721 481515
italforni@waicogroup.com - www.italforni.it

WAICO srl - Sede legale
Via Scotte, 1 - Isola Vicentina
36033 Vicenza (VI) Italia - Tel. +39 0445 1716598
info@waicogroup.com - www.waicogroup.com

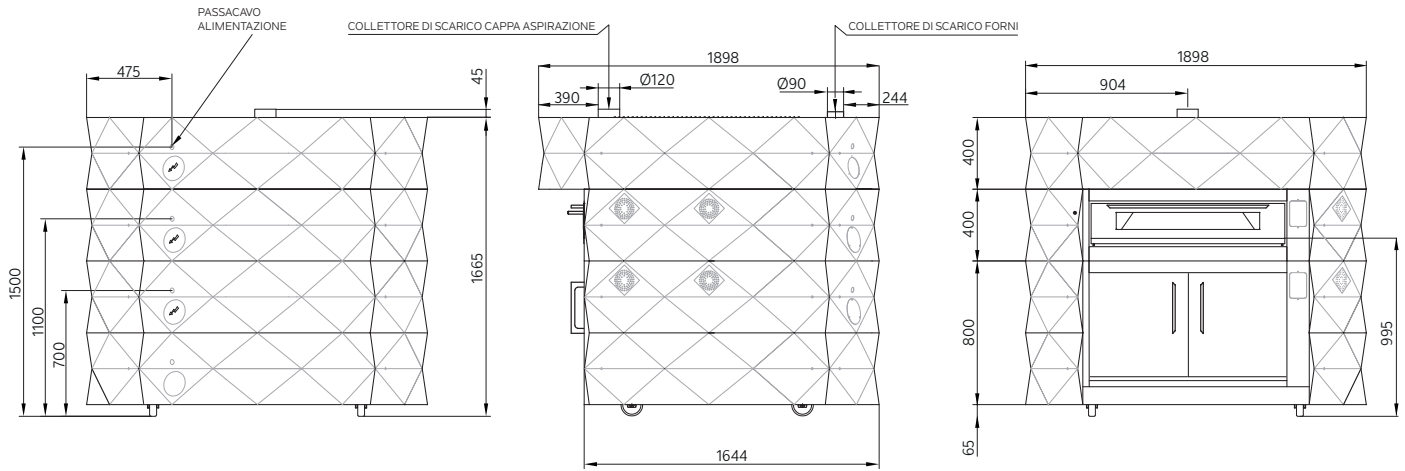
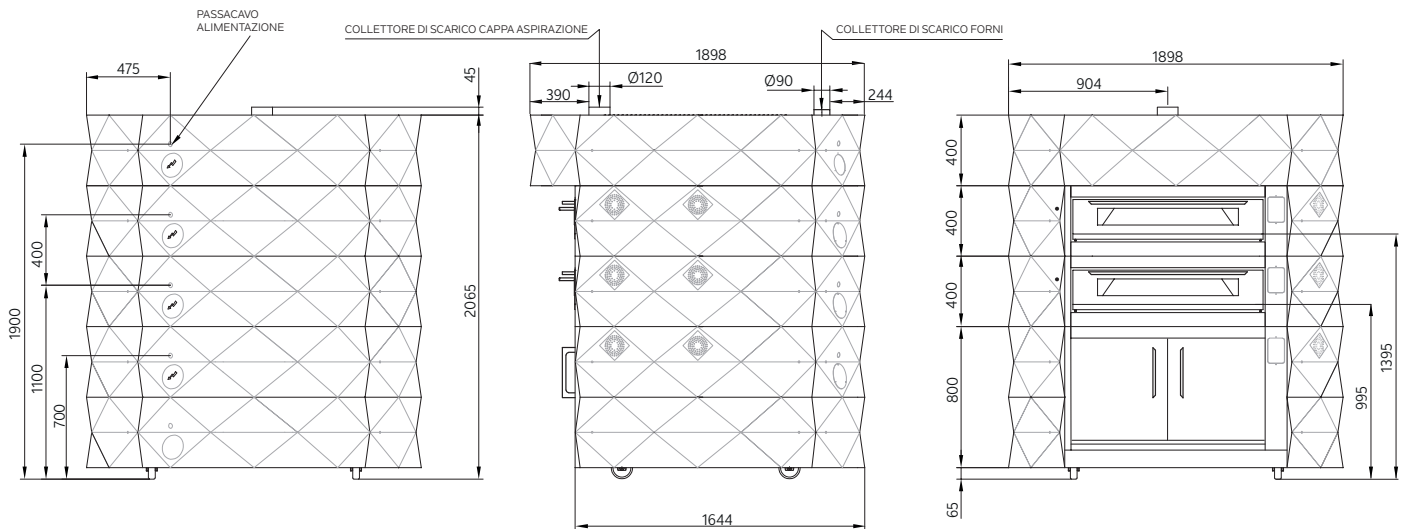
1-DIA - CS
1 CAMERA + CAPPRA + CELLA H700
1 CHAMBER + HOOD + PROVER H700

2-DIA - CS
2 CAMERE + CAPPRA + CELLA H700
2 CHAMBERS + HOOD + PROVER H700

**ITALFORNI È UN BRAND
DI WAICO GROUP**
ITALFORNI - Sede operativa
 Via dell'Industria, 130 - Loc. Chiusa di Ginestreto
 61122 Pesaro (PU) Italia - Tel. +39 0721 481515
 italforni@waicogroup.com - www.italforni.it

WAICO srl - Sede legale
 Via Scotte, 1 - Isola Vicentina
 36033 Vicenza (VI) Italia - Tel. +39 0445 1716598
 info@waicogroup.com - www.waicogroup.com

3-DIA - CS

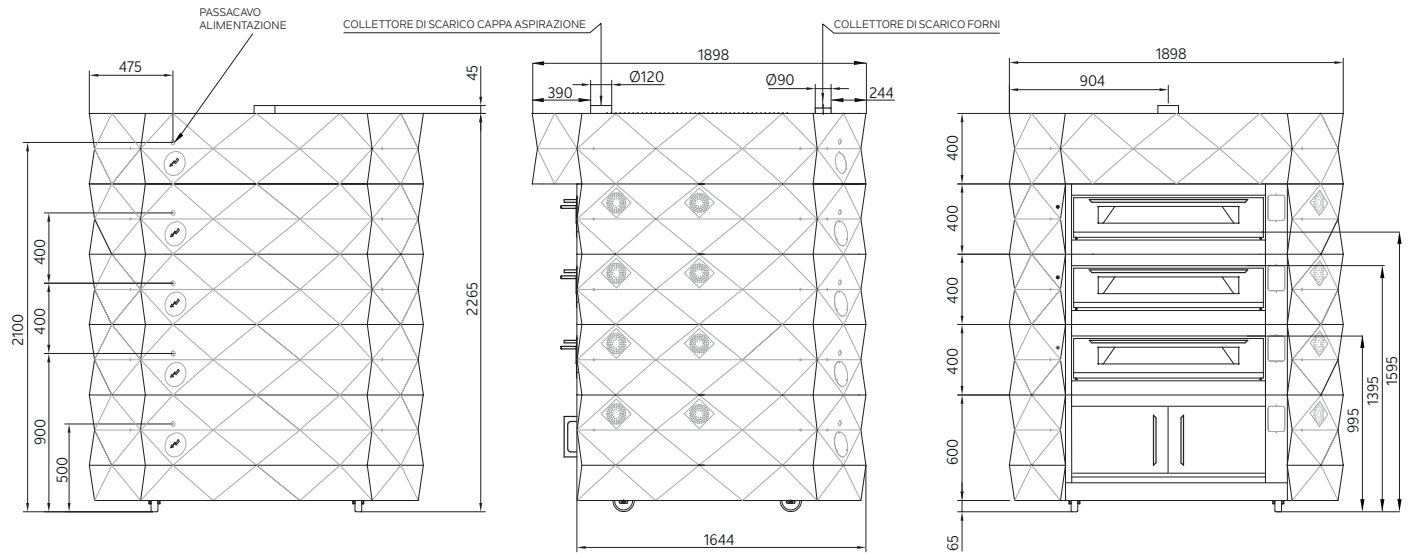
3 CAMERE + CAPPA + CELLA H500

3 CHAMBERS + HOOD + PROVER H500



**ITALFORNI È UN BRAND
DI WAICO GROUP**

ITALFORNI - Sede operativa
Via dell'Industria, 130 - Loc. Chiusa di Ginestreto
61122 Pesaro (PU) Italia - Tel. +39 0721 481515
italforni@waicogroup.com - www.italforni.it

WAICO srl - Sede legale
Via Scotte, 1 - Isola Vicentina
36033 Vicenza (VI) Italia - Tel. +39 0445 1716598
info@waicogroup.com - www.waicogroup.com

1-DIA - FM
1 CAMERA + CAPPRA + CELLA H700

1 CHAMBER + HOOD + PROVER H700

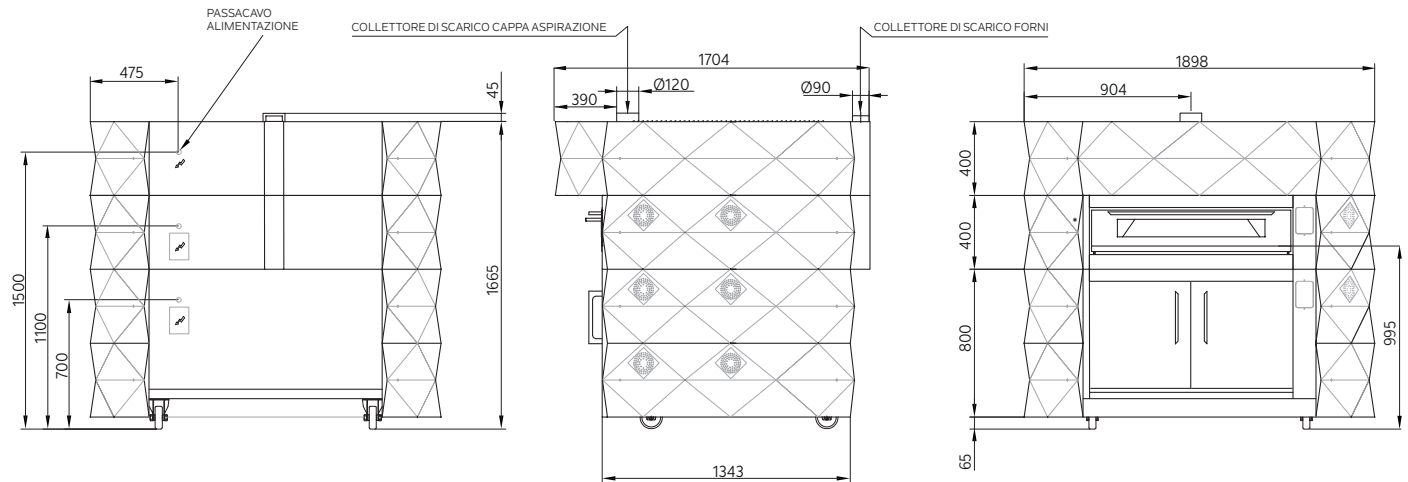
2-DIA - FM
2 CAMERE + CAPPRA + CELLA H700

2 CHAMBERS + HOOD + PROVER H700

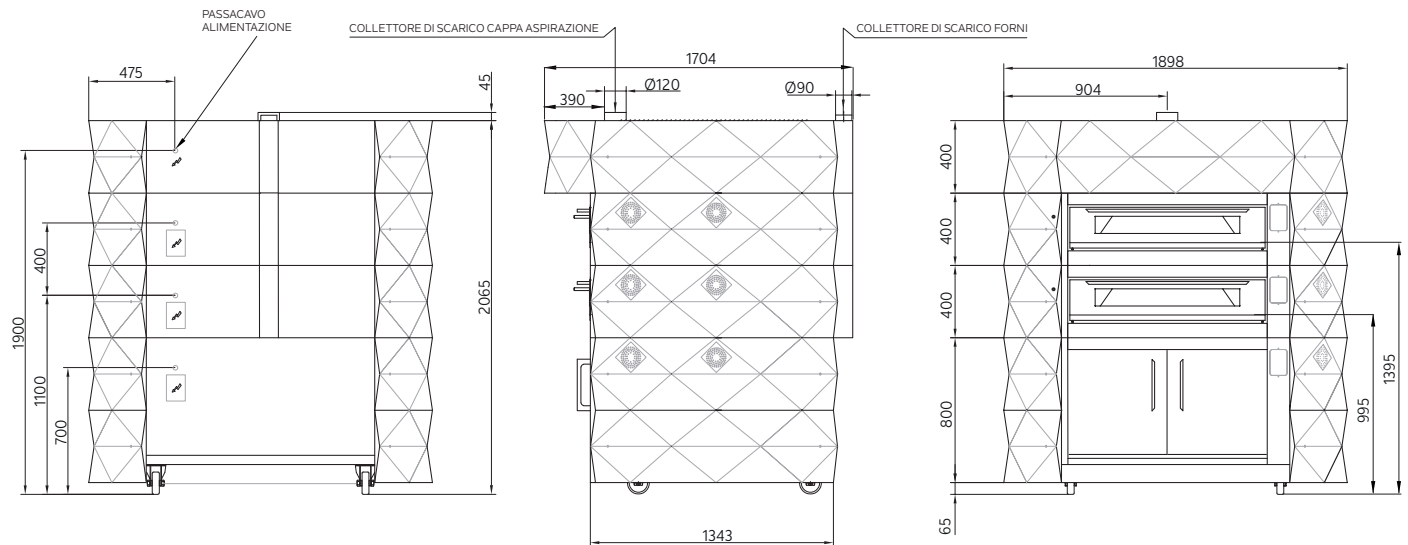
**ITALFORNI È UN BRAND
DI WAICO GROUP**

 ITALFORNI - Sede operativa
 Via dell'Industria, 130 - Loc. Chiusa di Ginestreto
 61122 Pesaro (PU) Italia - Tel. +39 0721 481515
 italforni@waicogroup.com - www.italforni.it

 WAICO srl - Sede legale
 Via Scotte, 1 - Isola Vicentina
 36033 Vicenza (VI) Italia - Tel. +39 0445 1716598
 info@waicogroup.com - www.waicogroup.com

3-DIA - FM

3 CAMERE + CAPPA + CELLA H500

3 CHAMBERS + HOOD + PROVER H500

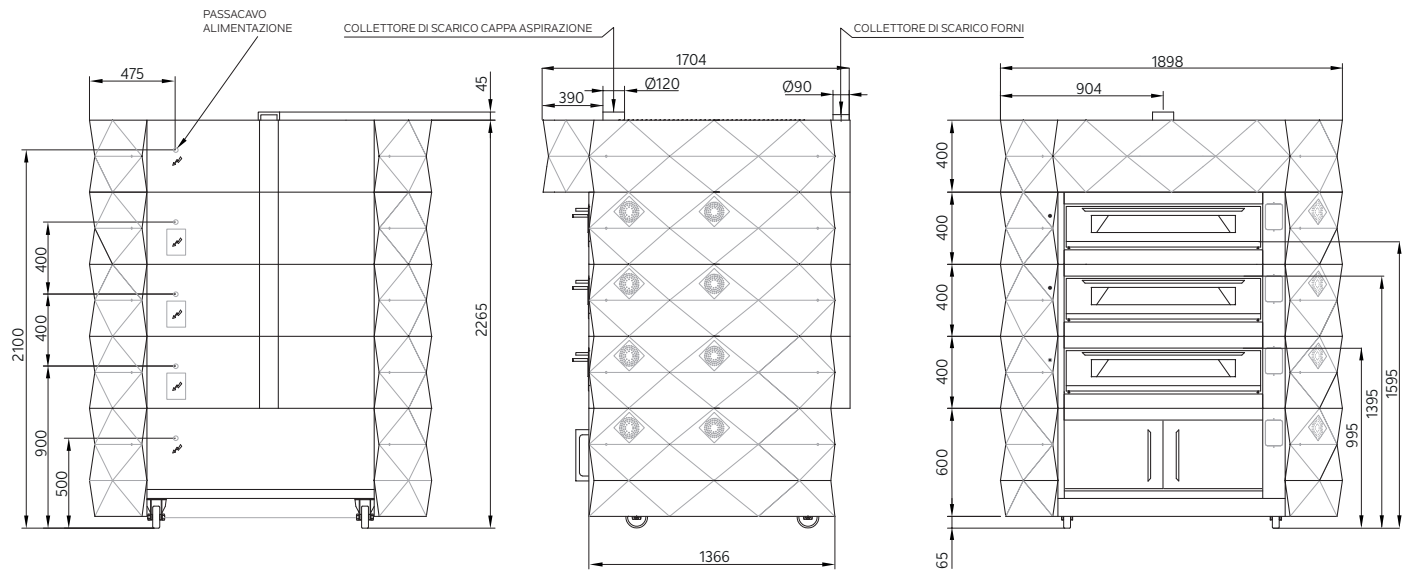

**ITALFORNI È UN BRAND
DI WAICO GROUP**

ITALFORNI - Sede operativa
Via dell'Industria, 130 - Loc. Chiusa di Ginestreto
61122 Pesaro (PU) Italia - Tel. +39 0721 481515
italforni@waicogroup.com - www.italforni.it

WAICO srl - Sede legale
Via Scotte, 1 - Isola Vicentina
36033 Vicenza (VI) Italia - Tel. +39 0445 1716598
info@waicogroup.com - www.waicogroup.com

3-DIA
3 CAMERE + CAPP
+ CELLA H500

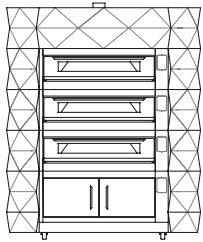

3 CHAMBERS +
HOOD +
PROVER H500

2-DIA
2 CAMERE + CAPP
+ CELLA H700

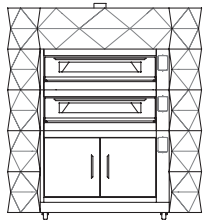

2 CHAMBERS +
HOOD +
PROVER H700

1-DIA
1 CAMERA + CAPP
+ CELLA H700

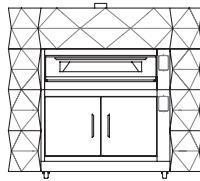

1 CHAMBER +
HOOD +
PROVER H700

CS
CENTRO STANZA
CENTRAL INSTALLATION

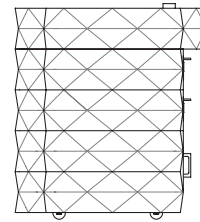

**CON CARTER
POSTERIORI**
WITH REAR
CARTERS

FM
FILO MURO
WALL INSTALLATION

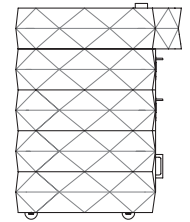

**SENZA CARTER
POSTERIORI**
WITHOUT REAR
CARTERS







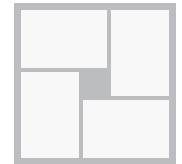
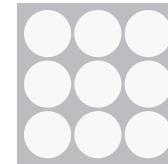

CAPACITÀ DI CARICO PER CAMERA
LOADING CAPACITY PER DECK

DIAMOND

DIMENSIONI INTERNE
Internal dimensions
A/H 17 x L/W 105 x P/D 105 cm
9 Pizze Ø 35 cm
4 Teglie 60x40 cm
4 Baking pans 60x40 cm



DATI TECNICI
TECHNICAL CHART

DIAMOND		Dimensioni interne Internal Dimensions (cm)			Dimensioni esterne External Dimensions (cm)			Peso Weight Kg	Alimentazione forno Supply Oven V/Ph/Hz	Alimentazione Cappa e Cella Supply Hood / Prover V/Ph/Hz	Potenza Power		Temperatura Temperature °C	N° Pizze # Pizze Ø 35 cm	N° Teglie # Baking pans 60x40 cm
		A/H	L/W	P/D	A/H	L/W	P/D				max. KW/h	med. KW/h			
F-DIA FORNO OVEN	CS 	17	105	105	40	190	170	260	400/3/50-60		11	5,5	0/460	9	4
	FM 	17	105	105	40	190	150	250	400/3/50-60		11	5,5	0/460	9	4
1-DIA	CS 	17	105	105	170	190	190	480	400/3/50-60	230/1/50-60	12,3	6,3	0/460	9	4
	FM 	17	105	105	170	190	170	450	400/3/50-60	230/1/50-60	12,3	6,3	0/460	9	4
2-DIA	CS 	17	105	105	210	190	190	740	400/3/50-60	230/1/50-60	23,3	11,8	0/460	18	8
	FM 	17	105	105	210	190	170	700	400/3/50-60	230/1/50-60	23,3	11,8	0/460	18	8
3-DIA	CS 	17	105	105	230	190	190	1000	400/3/50-60	230/1/50-60	34,3	17,3	0/460	27	12
	FM 	17	105	105	230	190	170	950	400/3/50-60	230/1/50-60	34,3	17,3	0/460	27	12

CS: centro stanza con carter posteriore / central installation with back plate - **FM:** filo muro senza carter posteriore / wall installation without backplate

**ITALFORNI È UN BRAND
DI WAICO GROUP**

ITALFORNI - Sede operativa
Via dell'Industria, 130 - Loc. Chiusa di Ginestreto
61122 Pesaro (PU) Italia - Tel. +39 0721 481515
italforni@waicogroup.com - www.italforni.it

WAICO srl - Sede legale
Via Scotte, 1 - Isola Vicentina
36033 Vicenza (VI) Italia - Tel. +39 0445 1716598
info@waicogroup.com - www.waicogroup.com



I dati riportati sul presente documento sono da ritenersi non vincolanti. Waico srl si riserva di apportare modifiche tecniche in qualsiasi momento.
The specifics shown in this document are to be considered not binding. Waico srl reserves the right to make technical changes at any moment.